



Viber Head Performance with VMG Gasoline Power Units								
Head Specifications					VMG-1750HH/BP		VMG-2500BP	
Diameter inches	Length inches	Weight pounds	Unbalance lb-in	Ave Amp (Peak-to-Peak)	Speed ³ rpm	Force pounds	Speed ² rpm	Force pounds
7/8	11.94	1.4	0.029	0.041	10,000	82	12,670	132
1	12.45	2.1	0.029	0.028	10,000	82	12,670	132
1 1/4	12.19	3.0	0.092	0.062	10,000	261	12,670	419
1 1/2	12.04	4.1	0.162	0.079	10,000	460	12,670	739
1 3/4	13.05	6.2	0.236	0.077	10,000	670	12,670	1,076
2 1/8	13.01	9.2	0.337	0.073	9,600	882	12,670	1,536
2 1/2	12.52	12.2	0.478	0.078	9,100	1,124	11,750	1,874
Special Purpose Heads								
7/8 Low Force	9.94	1.2	0.012	0.021	10,000	34	12,670	55
2 1/8 Shallow Pour	5.84	3.3	0.168	0.102	10,000	477	12,670	766
Unshaded	Best Performance.							
Shaded	Reduced Performance because speed is too high or too low. A 10% increase in speed reduces the head bearing life by 50%.							
¹ The speed provided above is an approximation of the head speed in concrete for the specified motor-head combination. The actual speed will vary depending on temperature, consistency of the concrete, the degree of brush wear, the hours on the bearings, etc. Running an electric motor with too large a head will slow the motor and can result in excess amp draw and heat generation with premature motor failure.								
² The speed provided above is an approximation of the head speed in concrete with the VMG-2500 Gasoline Engine Backpack Power Unit at maximum throttle. Unit operates at a maximum of 12,670 rpm. The actual speed will vary depending on temperature, consistency of the concrete, the hours on the bearings, etc.								
³ The speed provided above is an approximation of the head speed in concrete with the VMG-1750 Gasoline Engine Power Units at maximum throttle. Unit operates at a maximum of 10,000 rpm. The actual speed will vary depending on temperature, consistency of the concrete, the hours on the bearings, etc.								
⁴ The speed provided above is an approximation of the head speed in concrete with the VMP TURBO Pneumatic Power Unit with the control valve set for the appropriate head size. The actual speed will vary depending on temperature, consistency of the concrete the hours on the bearings, etc.								



Performance Data for Viber® VMG Gasoline Power Units

Model	Type	Weight pounds	HP Rating	Plug	Quick Disconnect	Maximum Head Size inches
VMG 1750HH	4-Cycle Gas	13.0	1.6 hp	None	Yes	1 ¾
VMG 1750BP	4-Cycle Gas	17.4	1.6 hp	None	Yes	1 ¾
VMG 2500BP	4-Cycle Gas	26.7	2.5 hp	None	Yes	2 ½

Gasoline Engine Concrete Vibrator VMG-1750 HH Comes with Quick Disconnect

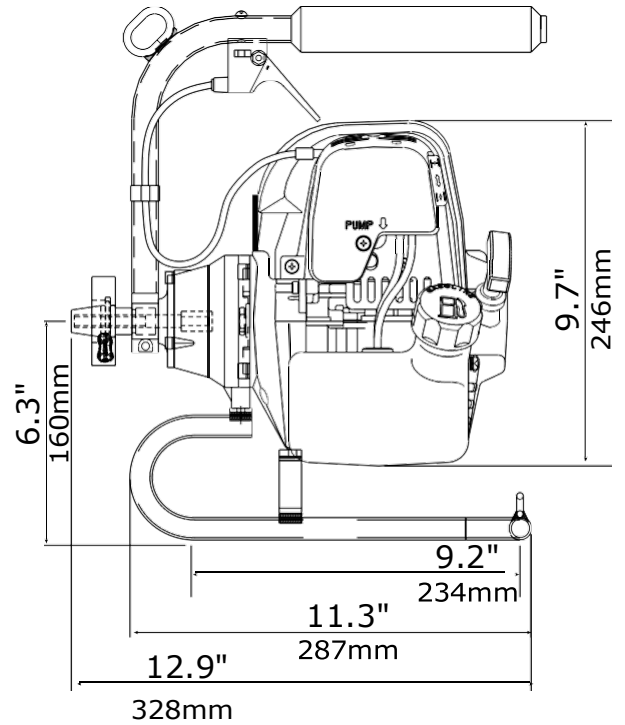
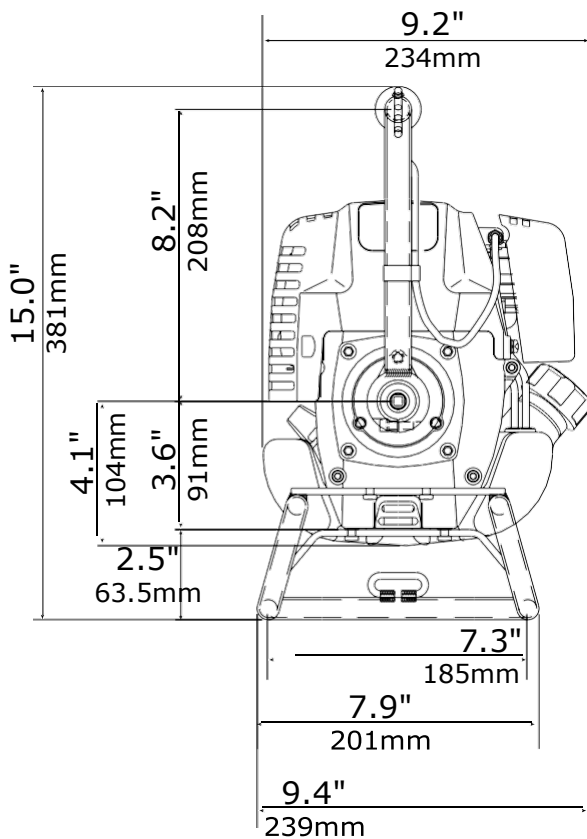
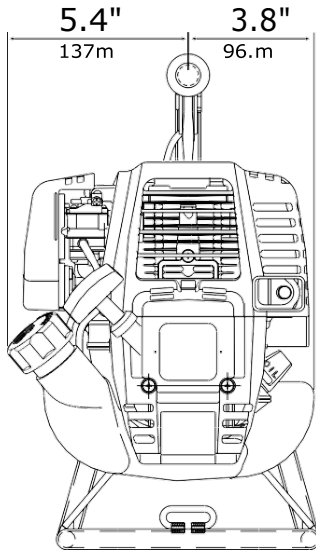



**Gasoline Engine Concrete Vibrator VMG-2500
BP Comes with Quick Disconnect**

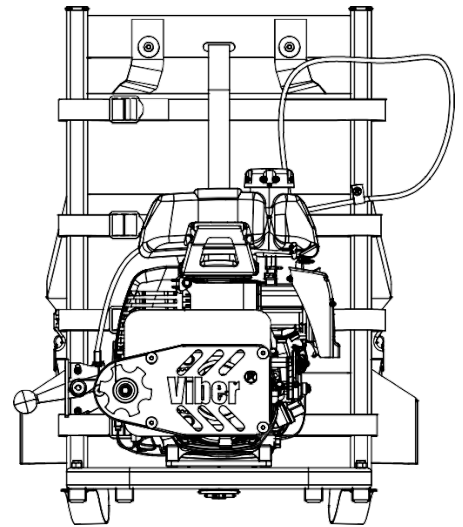
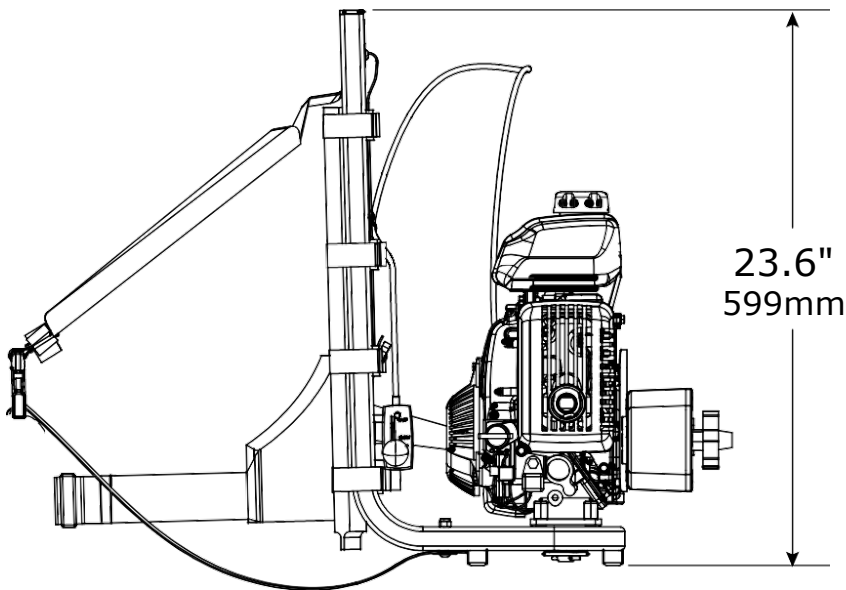
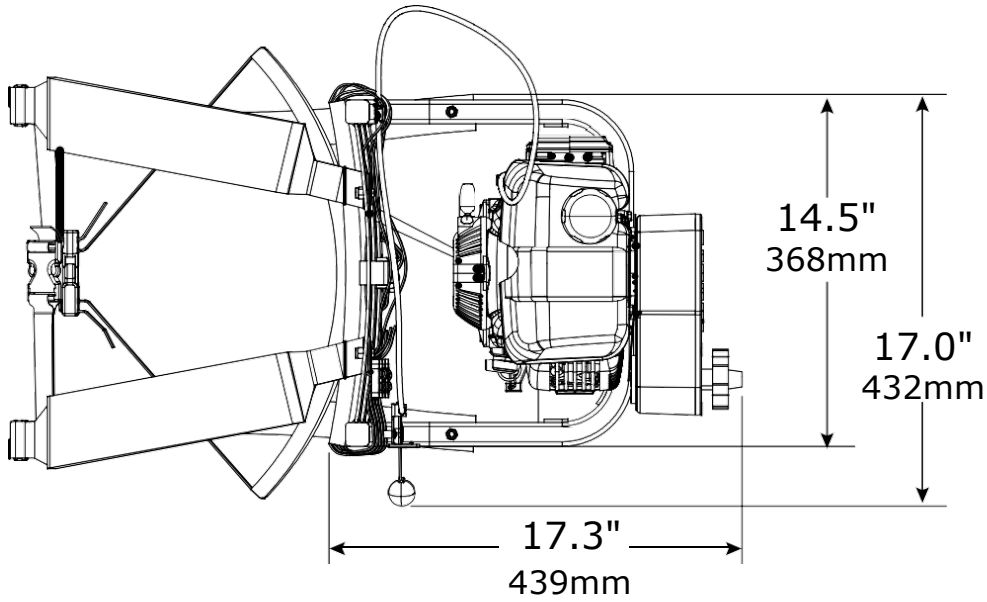

Distributed By:

ChicagoVibratorProducts
Flow and Compaction

Division of CVP Group

800-842-7284 (P)

866-247-7538 (F)

Solutions@ChiVib.com

www.ChicagoVibrator.com